













**3. DE Elektrischer Anschluss**  
**EN Electrical connection**

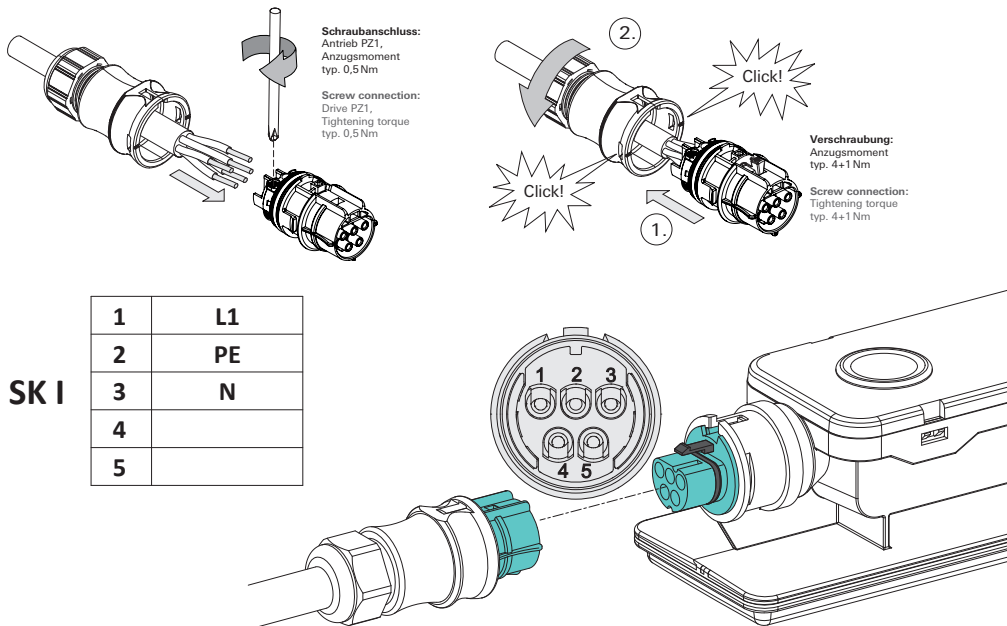
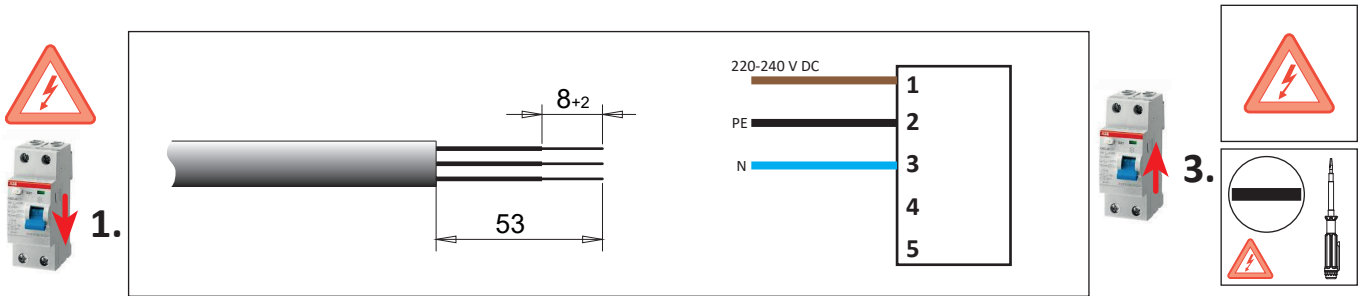

**DE Adressierung Notlicht Überwachungsbaustein**  
**EN Addressing emergency light monitoring module**

