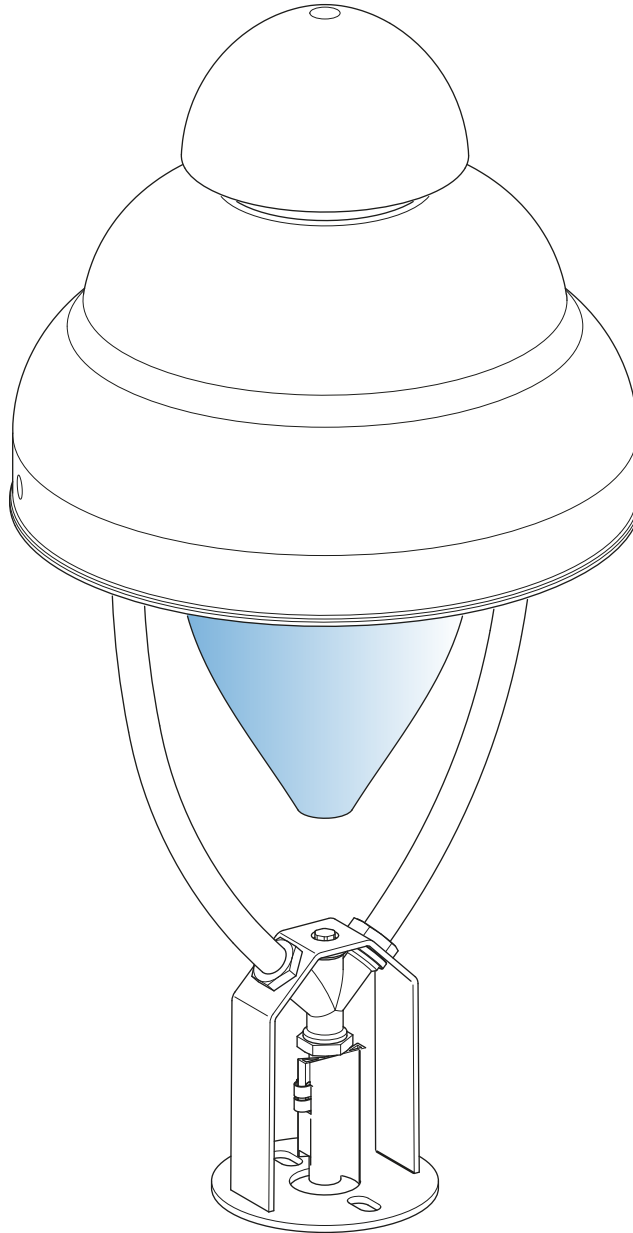
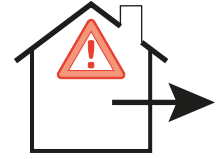

Gasleuchte 9655

DE Montageanleitung • EN Assembly instruction • FR Notice de montage • ES Instrucciones de instalación

**Lunux Lighting GmbH**

Zaucheweg 4
04316 Leipzig

Telefon +49 (0)341 241872 0
Telefax +49 (0)341 241872 38

info@lunux-lighting.com
www.lunux-lighting.com

DE Die Angaben können je nach Ausführung variieren. Technische Änderungen vorbehalten. Alle Angaben ohne Gewähr.

EN The details may vary depending on the model. Technical changes reserved. No liability assumed for details.

FR Les indications peuvent varier en fonction de l'exécution. Sous réserve de modification technique. Toutes les indications sans engagement.

ES Los datos pueden variar según versión. Reservado el derecho a realizar modificaciones técnicas. Todos los datos son sin garantía.

DE **Symbolerklärung**
 EN **Key to symbols**
 FR **Explication des symboles**
 ES **Explicación de símbolos**



DE **STOP!** Wichtiger Hinweis zur Warnung vor Personen- oder Sachschäden.
 EN **STOP!** Important warning notice relating to risk of injury or damage.
 FR **STOP!** Remarque importante pour prévenir des blessures corporelles ou des dommages matériels.
 ES **¡STOP!** Información importante de advertencia contra daños personales o materiales.



DE **Achtung!** Wichtiger Hinweis zur Warnung vor Personen- oder Sachschäden.
 EN **Caution!** Important warning notice relating to risk of injury or damage.
 FR **Attention!** Remarque importante pour prévenir des blessures corporelles ou des dommages matériels.
 ES **¡Atención!** Información importante de advertencia contra daños personales o materiales.



DE **Achtung!** Wichtiger Hinweis zur Warnung vor Stromschlaggefahr.
 EN **Caution!** Important warning notice relating to the risk of electric shock.
 FR **Attention!** Remarque importante pour prévenir des blessures corporelles ou des dommages matériels.
 ES **¡Atención!** Información importante de advertencia de peligro de descarga eléctrica.



DE Sicherungsautomat Leitung Spannungsfrei schalten.
 EN Circuit breaker De-energise the cable.
 FR Coupe-circuit automatique Mettre le câble hors tension.
 ES Protector automático Desconectar la línea de la red eléctrica.



DE **Achtung!** Wichtiger Hinweis zur Warnung vor Wasserschäden.
 EN **Caution!** Important warning notice relating to the risk of water damage.
 FR **Attention!** Remarque importante pour prévenir des dommages des eaux.
 ES **¡Atención!** Información importante de advertencia contra daños causados por agua.



DE Hinweis, Tipp oder Verweis
 EN Note, tip or reference
 FR Remarque, conseil ou renvoi
 ES Advertencia, consejo o referencia



DE Schalter EIN / AUS
 EN Switch ON/OFF
 FR Remarque, conseil ou renvoi
 ES Conexión ON / OFF



DE Optional
 EN Optional
 FR En option
 ES Opcional



DE Detailhinweis
 EN Detail note
 FR Remarque de détail
 ES Detalle indicación



DE Korrekte Montage
 EN Correct installation
 FR Montage correct
 ES Montaje correcto



DE Mit Kraftaufwand
 EN With high physical effort
 FR Nécessite de la force physique
 NL Met krachtsinspanning



DE Falsche Montage
 EN Incorrect installation
 FR Montage erroné
 ES Montaje incorrecto



DE Nur für den Außenbereich.
 EN Only for outdoor use.
 FR uniquement pour une utilisation en extérieur
 ES Sólo para uso al aire libre.

DE Allgemeine Sicherheitshinweise und Informationen
EN General safety instructions and information



- DE**
- Die Montage und Wartung ist grundsätzlich nur von einem autorisierten Fachpersonal vorzunehmen.
 - Vor der Verkabelung ist sicherzustellen, dass die Leitungen Spannungsfrei sind. Während der Verkabelung ist sicherzustellen, dass die Leitungen Spannungsfrei bleiben. (z. B. Wiedereinschalten verhindern)
 - Für die Installation und für den Betrieb dieser Leuchte sind die nationalen Sicherheitsvorschriften zu beachten
 - Der Hersteller übernimmt keine Haftung für Schäden, die durch unsachgemäßen Einsatz oder Montage entstehen.
 - Werden nachträglich Änderungen an der Leuchte vorgenommen, so gilt derjenige als Hersteller, der diese Änderungen vornimmt.
 - Zur Vermeidung von Gefährdungen darf die Leuchte nur in Betrieb genommen werden, wenn keine offensichtlichen Beschädigungen von Komponenten insbesondere der Anschlussleitung vorhanden sind.
 - Der Austausch von defekten Komponenten darf nur vom Hersteller vorgenommen werden.



- Die in dieser Leuchte enthaltenen Lichtquelle darf nur durch den Hersteller oder seinen Kundendienst oder eine ähnlich qualifizierte Person ersetzt werden.



- + Alle Maßangaben sind in mm.
- + Die Zeichnungen sind nicht maßstabsgerecht.
- + Technische Änderungen bleiben vorbehalten.



- EN**
- Installation and maintenance must be performed by authorised and trained staff.
 - Before wiring, make sure that the cables are de-energised. During wiring work, make sure that the cables remain de-energised. (e.g. prevent switching back on)
 - Observe your national safety regulations for the installation and use of this lamp.
 - The manufacturer accepts no liability for injuries or damage caused by unintended use or incorrect installation.
 - If the lamp is retroactively modified, the person who made the modifications then becomes the manufacturer.
 - To avoid risks, the lamp must only be operated if there are no visible signs of damage to components, in particular to the connecting cable.
 - Only the manufacturer is authorised to replace defective components.



- The light source contained in this luminaire shall only be replaced by the manufacturer or his service agent or a similar qualified person.



- + All dimensions stated in mm.
- + The drawings are not to scale.
- + Technical changes are reserved.

FR Consignes de sécurité et informations générales
ES Advertencias generales e informaciones de seguridad



- FR**
- Le montage et l'entretien sont fondamentalement et strictement réservés à un personnel spécialisé autorisé.
 - Avant le câblage, assurer que les câbles sont hors tension. Assurer pendant le câblage que les câbles restent hors tension (par ex. empêcher toute remise en service).
 - Respecter les réglementations de sécurité nationales pour l'installation et l'utilisation de cette lampe.
 - Le fabricant rejette toute responsabilité pour les dommages qui résultent de la mise en oeuvre ou du montage incorrects.
 - S'il est procédé ultérieurement à des modifications de la lampe, alors celui qui procède aux modifications est considéré comme le fabricant.
 - Pour éviter les risques, il est permis de mettre la lampe en service uniquement lorsque les composants, et en particulier le câble de raccordement, ne présentent aucun dommage visible.
 - Seul le fabricant est habilité à procéder au remplacement de composants défectueux.



- La source de lumière contenue dans ce luminaire ne doit être remplacé par le fabricant ou son agent de service ou une personne qualifiée.



- + Toutes les indications de mesure sont en mm.
- + Les schémas ne sont pas à l'échelle.
- + Sous réserve de modifications techniques.



- ES**
- El montaje y el mantenimiento serán realizados sólo por personal especializado debidamente autorizado.
 - Antes de realizar el cableado se comprobará que los cables están desconectados de la red eléctrica. Durante el cableado se asegurará que los cables se mantienen libres de tensión. (Por ejemplo, impedir una reconexión)
 - Para la instalación y el uso de esta lámpara se cumplirán las normas nacionales de seguridad.
 - El fabricante no asume responsabilidad alguna por daños causados por un uso o un montaje inadecuados.
 - Si se realizan modificaciones posteriores en la lámpara, se considerará fabricante al que haya realizado dicha modificación.
 - Par evitar peligros, la lámpara se utilizará solo cuando no existan daños visibles en sus componentes, y sobre todo en su cable de conexión.
 - La sustitución de componentes defectuosos solo podrá ser realizada por el fabricante.







- La fuente de luz contenida en esta luminaria sólo podrá ser sustituido por el fabricante o su agente de servicio o una persona calificada similares.



- + Todas las dimensiones son en mm.
- + Los dibujos no son a escala.
- + Reservado el derecho a realizar modificaciones técnicas.

IP65		
-------------	---	---

	W			
LED	31		✓	8,5

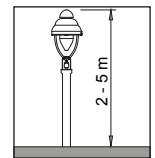
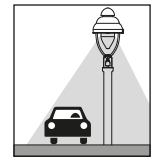
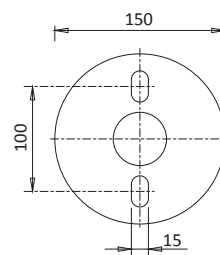
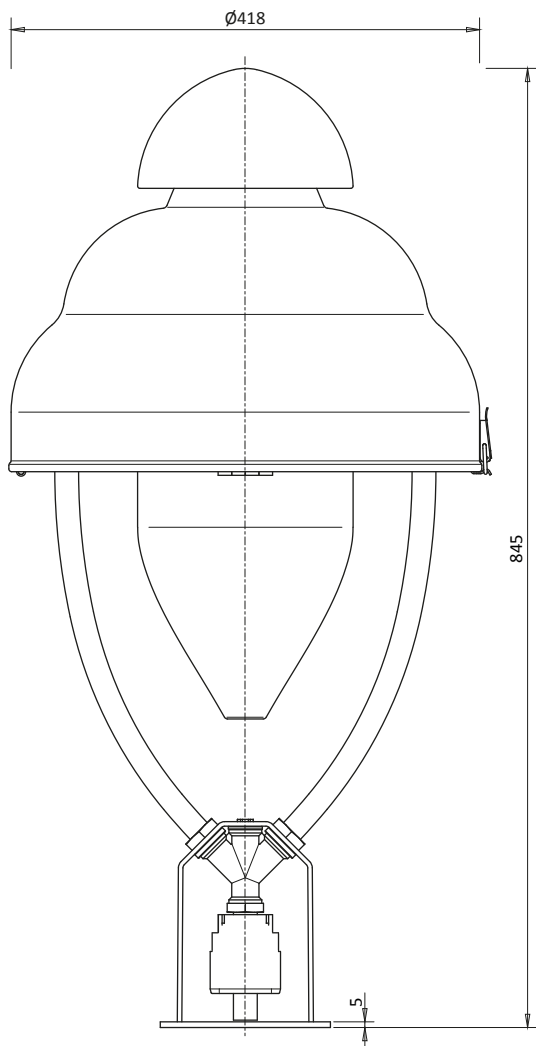

DE Netzanschluss 230V~, 50/60 Hz
Max. 0,07 A
Max. 31 W

FR Branchement secteur 230V~, 50/60 Hz
Max. 0,07 A
Max. 31 W

EN Mains connection 230V~, 50/60 Hz
Max. 0,07 A
Max. 31 W

ES Conexión a la red 230V~, 50/60 Hz
Máx. 0,07 A
Máx. 31 W

1. DE Lieferumfang
 EN Scope of delivery
 FR Fourniture
 ES Volumen de suministro

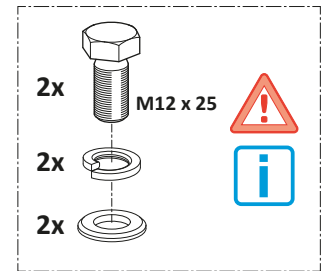
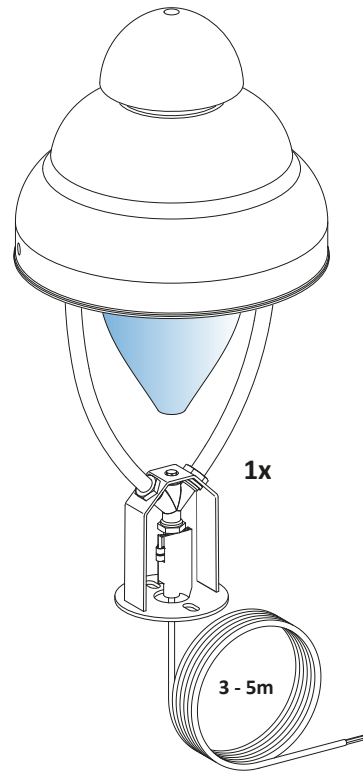

2. DE Montage
 EN Installation
 FR Montage
 ES Montaje

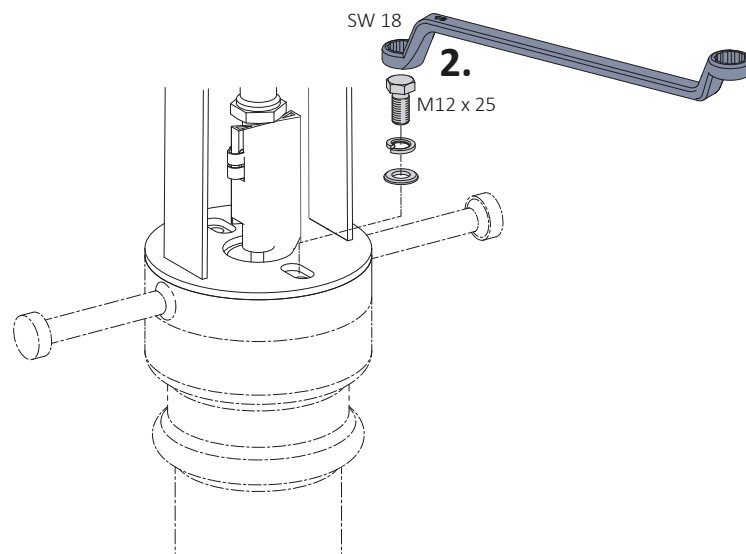
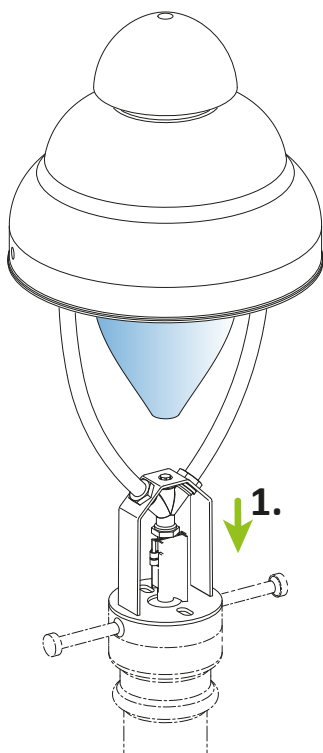
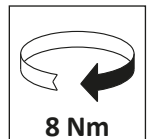
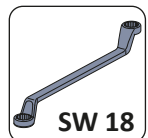

3. DE Elektrischer Anschluss
 EN Installation
 FR Branchement électrique
 ES Conexión eléctrica

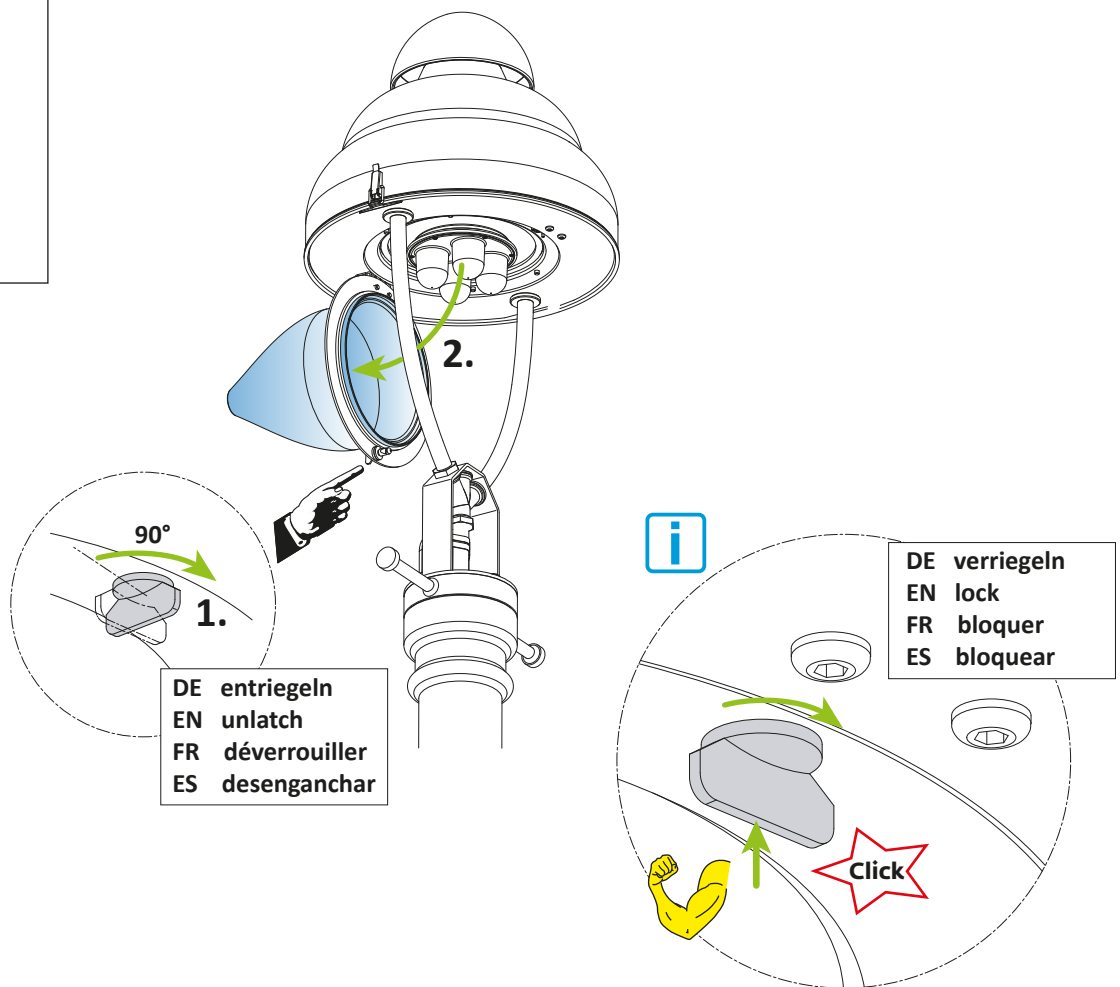
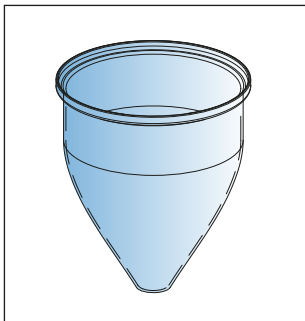
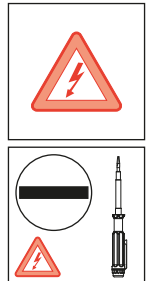

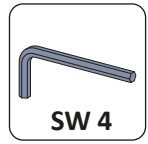
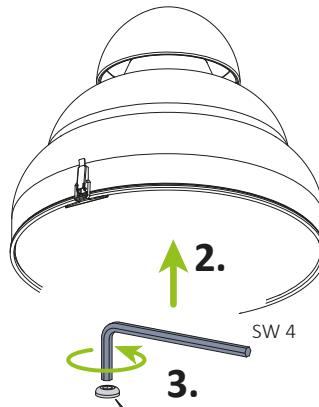
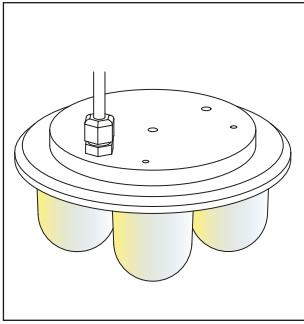

DE entriegeln
 EN unlatch
 FR déverrouiller
 ES desenganchar

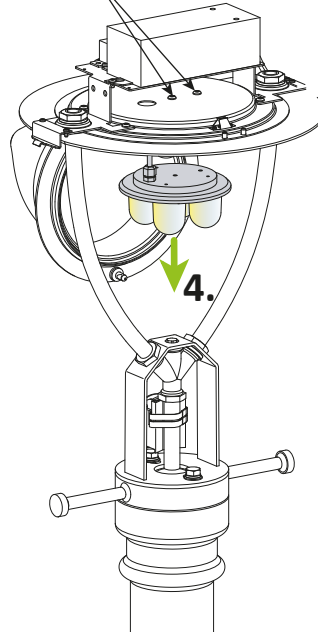
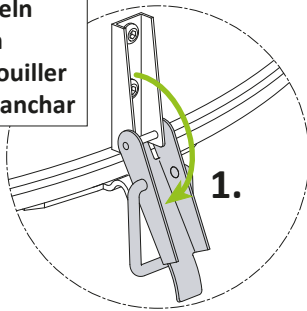

DE verriegeln
 EN lock
 FR bloquer
 ES bloquear

