

# Q-Rail Next Lichtbandsystem

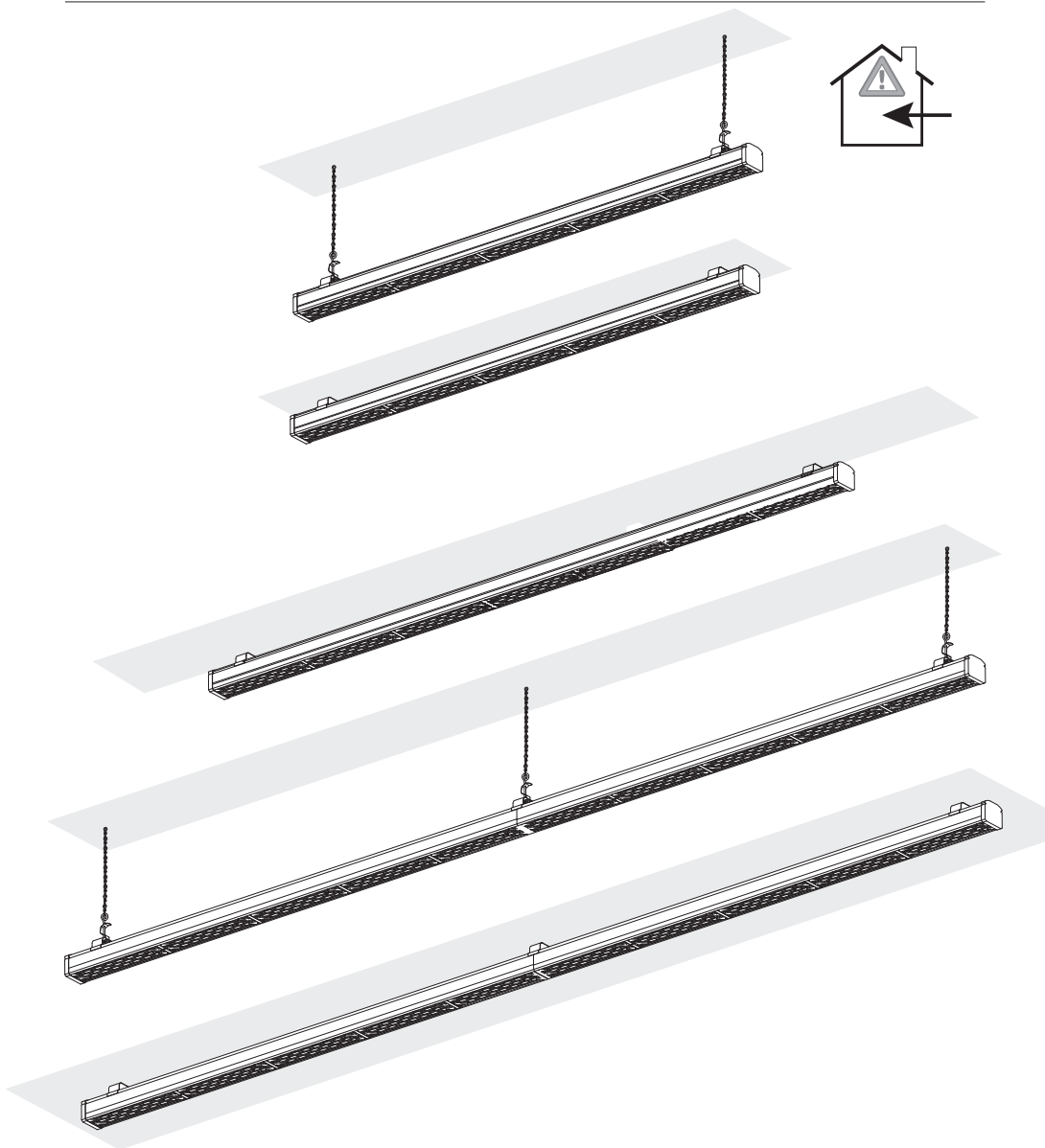

DE Installationsanleitung • EN Instruction manual • FR Instructions d'installation • ES Instrucciones de instalación • IT Manuale di installazione



**Lunux Lighting GmbH**  
Pittlerstraße 29  
04159 Leipzig

Telefon: +49 (0) 341 241 872 0  
Telefax: +49 (0) 341 241 872 38

[info@lunux-lighting.com](mailto:info@lunux-lighting.com)

**DE** Die Angaben können je nach Ausführung variieren. Technische Änderungen vorbehalten. Alle Angaben ohne Gewähr.

**EN** The details may vary depending on the model. Technical changes reserved. No liability assumed for details.

**FR** Les indications peuvent varier en fonction de l'exécution. Sous réserve de modification technique. Toutes les indications sans engagement.

**ES** Los datos pueden variar según versión. Reservado el derecho a realizar modificaciones técnicas. Todos los datos son sin garantía.

**IT** I dati possono variare secondo la versione. Riservato il diritto di modifiche tecniche. Tutti i dati senza garanzia.

80005164 EDL\_AI\_4L\_072017\_V3.0

DE **Symbolerklärung**  
 EN **Key to symbols**  
 FR **Explication des symboles**  
 ES **Explicación de símbolos**  
 IT **Spiegazione dei simboli**



DE **STOP!** Wichtiger Hinweis zur Warnung vor Personen- oder Sachschäden.  
 EN **STOP!** Important warning notice relating to risk of injury or damage.  
 FR **STOP!** Remarque importante pour prévenir des blessures corporelles ou des dommages matériels.  
 ES **¡STOP!** Información importante de advertencia contra daños personales o materiales.  
 IT **STOP!** Informazione importante per prevenire danni personali o materiali.



DE **Achtung!** Wichtiger Hinweis zur Warnung vor Personen- oder Sachschäden.  
 EN **Caution!** Important warning notice relating to risk of injury or damage.  
 FR **Attention!** Remarque importante pour prévenir des blessures corporelles ou des dommages matériels.  
 ES **¡Atención!** Información importante de advertencia contra daños personales o materiales.  
 IT **Attenzione!** Informazione importante per prevenire danni personali o materiali.



DE **Achtung!** Wichtiger Hinweis zur Warnung vor Stromschlaggefahr.  
 EN **Caution!** Important warning notice relating to the risk of electric shock.  
 FR **Attention!** Remarque importante pour prévenir des chocs électriques.  
 ES **¡Atención!** Información importante de advertencia de peligro de descarga eléctrica.  
 IT **Attenzione!** Nota importante su come prevenire folgorazioni di corrente.



DE Sicherungsautomat  
 EN Circuit breaker  
 FR Coupe-circuit automatique  
 ES Protector automático  
 IT Interruttore automatico

Leitung spannungsfrei schalten.  
 De-energise the cable.  
 Mettre le câble hors tension.  
 Desconectar la línea de la red eléctrica.  
 Disconnettere la linea dalla rete elettronica.



DE **Achtung!** Wichtiger Hinweis zur Warnung vor Wasserschäden.  
 EN **Caution!** Important warning notice relating to the risk of water damage.  
 FR **Attention!** Remarque importante pour prévenir des dommages des eaux.  
 ES **¡Atención!** Información importante de advertencia contra daños causados por agua.  
 IT **Attenzione!** Nota importante per prevenire danni causati dall'acqua.



DE Hinweis, Tipp oder Verweis  
 EN Note, tip or reference  
 FR Remarque, conseil ou renvoi  
 ES Advertencia, consejo o referencia  
 IT Avviso, consiglio o riferimento



DE Schalter EIN/AUS  
 EN Switch ON/OFF  
 FR Interrupteur ON/OFF  
 ES Conexión ON/OFF  
 IT Pulsante ON/OFF



DE Optional  
 EN Optional  
 FR En option  
 ES Opcional  
 IT Opzionale



DE Detailhinweis  
 EN Detail note  
 FR Remarque de détail  
 ES Detalle indicación  
 IT Indicazione di dettaglio



DE Korrekte Installation  
 EN Correct installation  
 FR Installation correcte  
 ES Instalación correcta  
 IT Installazione corretta



DE Mit Kraftaufwand  
 EN With high physical effort  
 FR Nécessité de la force physique  
 ES Con esfuerzo  
 IT Con impiego di forza



DE Falsche Installation  
 EN Incorrect installation  
 FR Installation incorrecte  
 ES Instalación incorrecta  
 IT Installazione sbagliata



DE Nur für den Innenbereich.  
 EN Only for indoor use.  
 FR Uniquement pour une utilisation en intérieur.  
 ES Sólo para uso al aire libre.  
 IT Solo per l'utilizzo al interno.

**DE Allgemeine Sicherheitshinweise und Informationen**  
**EN General safety instructions and information**  
**FR Consignes de sécurité et informations générales**



- DE**
- Die Installation und Wartung ist grundsätzlich nur von autorisiertem Fachpersonal vorzunehmen.
  - Vor der Verkabelung ist sicherzustellen, dass die Leitungen spannungsfrei sind. Während der Verkabelung ist sicherzustellen, dass die Leitungen spannungsfrei bleiben (z. B. Wiedereinschalten verhindern).
  - Für die Installation und für den Betrieb dieser Leuchte sind die nationalen Sicherheitsvorschriften zu beachten.
  - Der Hersteller übernimmt keine Haftung für Schäden, die durch unsachgemäßen Einsatz oder Installation entstehen.
  - Werden nachträglich Änderungen an der Leuchte vorgenommen, so gilt derjenige als Hersteller, der diese Änderungen vornimmt.
  - Zur Vermeidung von Gefährdungen darf die Leuchte nur in Betrieb genommen werden, wenn keine offensichtlichen Beschädigungen von Komponenten insbesondere der Anschlussleitung vorhanden sind.
  - Der Austausch von defekten Komponenten darf nur vom Hersteller vorgenommen werden.
  - Die Lichtquelle dieser Leuchte ist nicht ersetzbar; wenn die Lichtquelle ihr Lebensdauerende erreicht hat, ist die gesamte Leuchte zu ersetzen.



- + Alle Maßangaben sind in mm.
- + Die Zeichnungen sind nicht maßstabgerecht.
- + Technische Änderungen bleiben vorbehalten.



- EN**
- Installation and maintenance must be performed by authorised and trained staff.
  - Before wiring, make sure that the cables are de-energised. During wiring work, make sure that the cables remain de-energised (e.g. prevent switching back on).
  - Observe your national safety regulations for the installation and use of this lamp.
  - The manufacturer accepts no liability for injuries or damage caused by unintended use or incorrect installation.
  - If the lamp is retroactively modified, the person who made the modifications then becomes the manufacturer.
  - To avoid risks, the lamp must only be operated if there are no visible signs of damage to components, in particular to the connecting cable.
  - Only the manufacturer is authorised to replace defective components.
  - The light source contained in this luminaire shall only be replaced by the manufacturer or his service agent or a similarly qualified person.



- + All dimensions stated in mm.
- + The drawings are not to scale.
- + Technical changes are reserved.



- FR**
- L'installation et l'entretien sont fondamentalement et strictement réservés à un personnel spécialisé autorisé.
  - Avant le câblage, assurer que les câbles sont hors tension. Assurer pendant le câblage que les câbles restent hors tension (par ex. empêcher toute remise en service).
  - Respecter les réglementations de sécurité nationales pour l'installation et l'utilisation de cette lampe.
  - Le fabricant rejette toute responsabilité pour les dommages qui résultent de l'usage ou du installation incorrect.
  - S'il est procédé ultérieurement à des modifications de la lampe, alors celui qui procède aux modifications est considéré comme le fabricant.
  - Pour éviter les risques, il est permis de mettre la lampe en service uniquement lorsque les composants, et en particulier le câble de raccordement, ne présentent aucun dommage visible.
  - Seul le fabricant est habilité à procéder au remplacement de composants défectueux.
  - La source de lumière contenue dans ce luminaire ne doit être remplacé que par le fabricant ou son agent de service ou une personne qualifiée.



- + Toutes les indications de mesure sont en mm.
- + Les schémas ne sont pas à l'échelle.
- + Sous réserve de modifications techniques.

---

**ES**    **Indicaciones de seguridad e información general**  
**IT**    **Avvisi di sicurezza ed informazioni generali**



**ES**

- La instalación y el mantenimiento serán realizados sólo por personal especializado debidamente autorizado.
- Antes de realizar el cableado se comprobará que los cables están desconectados de la red eléctrica. Durante el cableado se asegurará que los cables se mantienen libres de tensión (Por ejemplo, impedir una reconexión).
- Para la instalación y el uso de esta lámpara se cumplirán las normas nacionales de seguridad.
- El fabricante no asume responsabilidad alguna por daños causados por o una utilización inadecuada.
- Si se realizan modificaciones posteriores en la lámpara, se considerará fabricante al que haya realizado dicha modificación.
- Par evitar peligros, la lámpara se utilizará solo cuando no existan daños visibles en sus componentes, y sobre todo en su cable de conexión.
- La sustitución de componentes defectuosos solo podrá ser realizada por el fabricante.
- La fuente de luz contenida en esta luminaria sólo podrá ser sustituida por el fabricante o su agente de servicio o una persona con una cualificación similar.



- + Todas las dimensiones son en mm.
- + Los dibujos no son a escala.
- + Reservado el derecho a realizar modificaciones técnicas.



**IT**

- L'installazione e la manutenzione devono essere effettuati solamente tramite personale specializzato autorizzato.
- Prima di realizzare il cablaggio è importante verificare che i cavi siano disconnessi dalla rete elettrica. Durante il cablaggio deve essere assicurato che i cavi restino senza tensione (per esempio, impedire la rimessa in tensione).
- Per l'installazione e l'uso di questi apparecchi devono essere rispettate le norme di sicurezza nazionali.
- Il fabbricante non si assume responsabilità per danni causati da un uso o un'installazione errata.
- Nel caso vengano apportate delle modifiche all'apparecchio, si ritiene come fabbricante colui che ha effettuato tali modifiche.
- Per evitare pericoli, l'apparecchio si utilizzerà solo quando non esistono danni visibili dei suoi componenti e soprattutto di connessione.
- La sostituzione dei componenti può essere effettuata solo dal fabbricante.
- La fonte di luce in questo apparecchio può essere sostituita solo dal fabbricante, il suo servizio clienti o una persona con qualifiche analoghe.



- + Tutte le dimensioni sono in mm.
- + I disegni riportati non sono in scala.
- + Riservato il diritto di realizzare modifiche tecniche.

IP20



	A		
LED	max. 16 A	✓	3.2 Kg pro 1.5 m

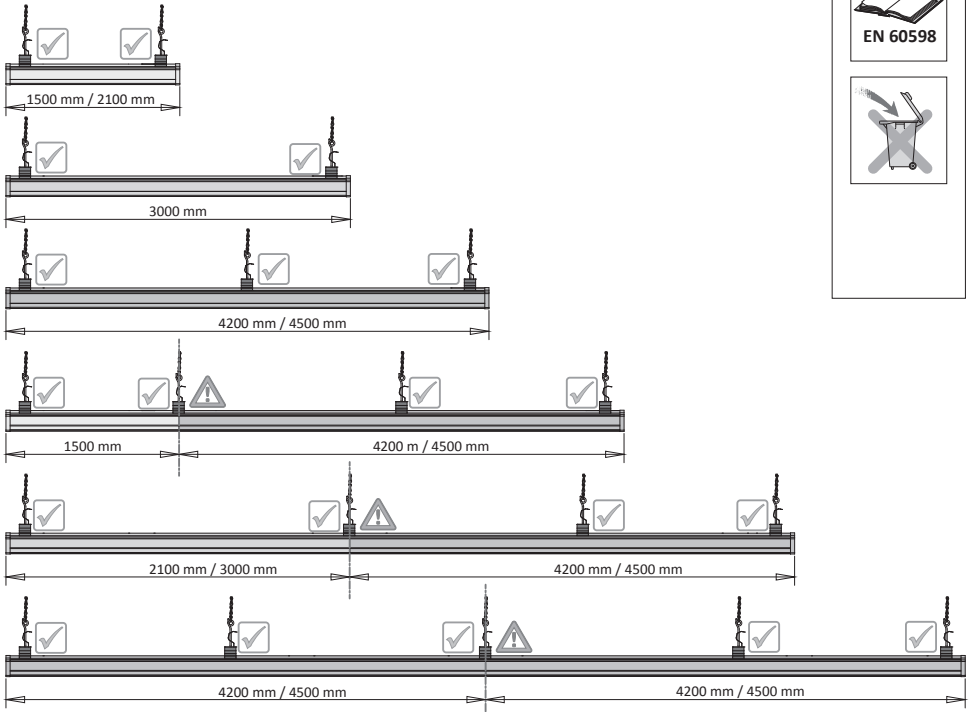
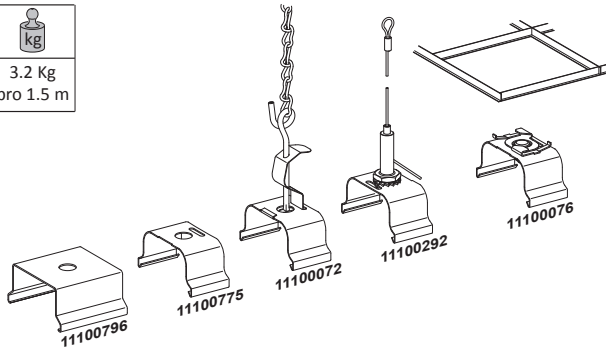

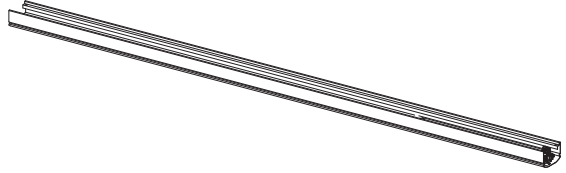

1. DE Tragschiene  
 EN Carrier rail  
 FR Rail de support  
 ES Carril portador  
 IT Rotaia portante

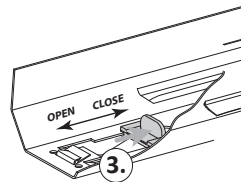
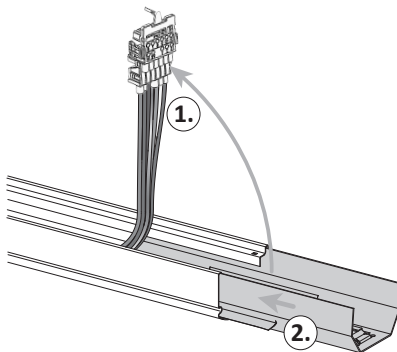
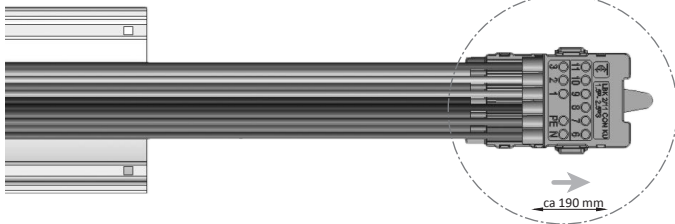
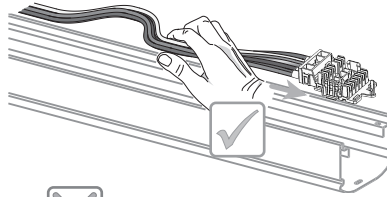

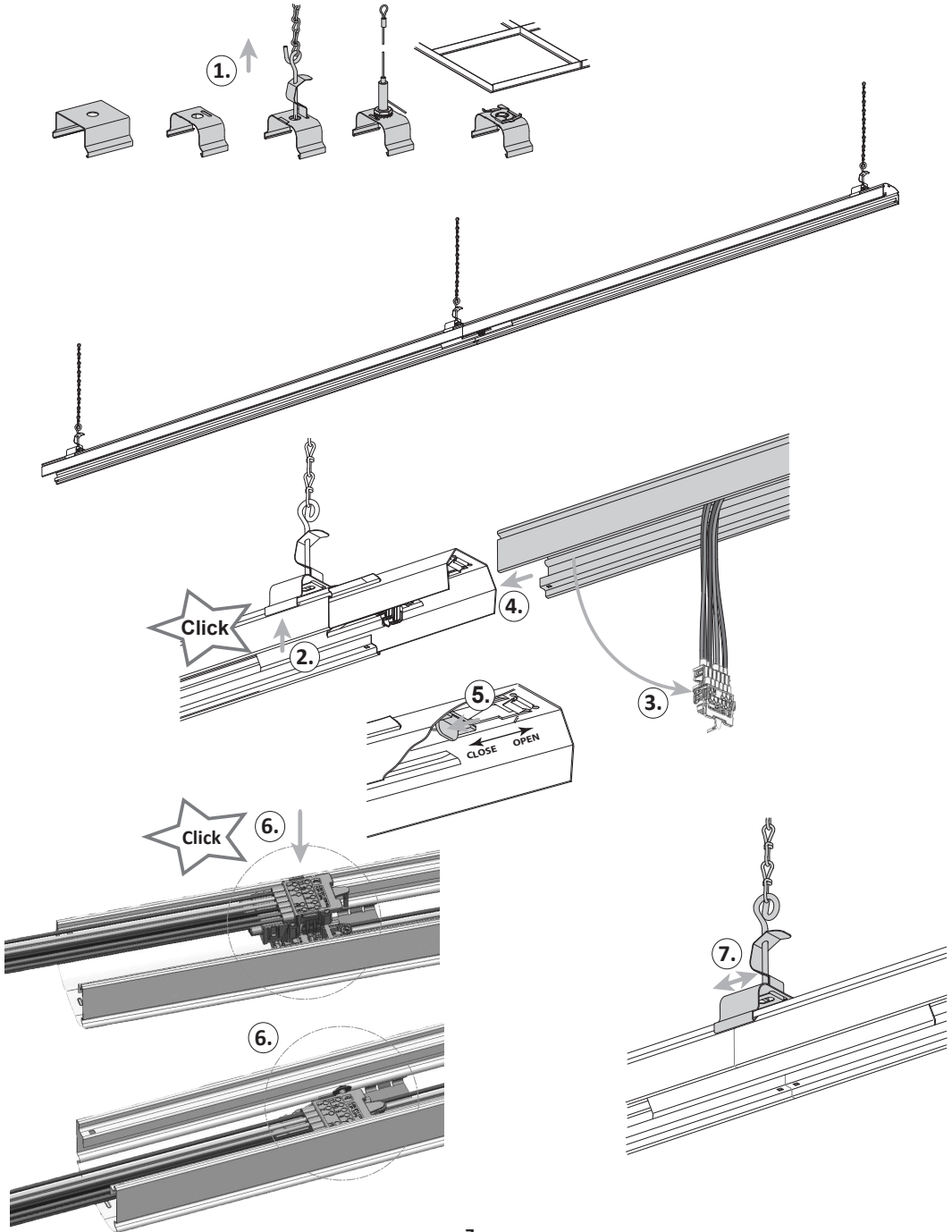

2. DE Elektrischer Anschluss  
 EN Electrical connection  
 FR Branchement électrique  
 ES Conexión eléctrica  
 IT Connessione elettrica



**NOTICE FOR DALI!**

DE Basis Isolation - DALI-Anschlussleistung Netzspannungsfest auslegen!  
 EN Basic insulation - DALI connection according to mains voltage!  
 FR Isolement de base - Conception de la connexion DALI en fonction de la tension du secteur!  
 ES Aislamiento básico - Diseñe la conexión DALI según la tensión de red!  
 IT Isolamento di base - Progettare la connessione DALI in base alla tensione di rete!

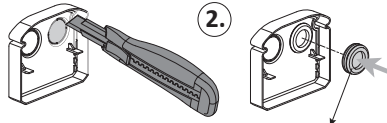

DE Nicht im Lieferumfang enthalten.  
 EN Not included in delivery.  
 FR Ils ne sont pas inclus dans la livraison.  
 ES No incluido en el suministro.  
 IT Non incluso nella fornitura.

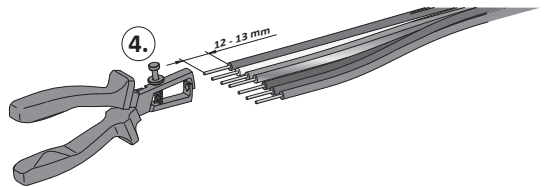
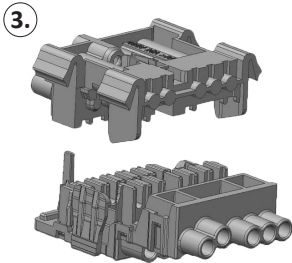

Artikelnummer: 70017084

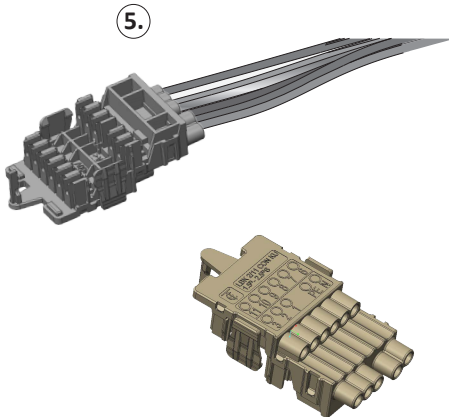

1 schwarz / black		L1
2 braun / brown		L2
3 grau / grey		L3
4 blau / blue		N
5 grün/gelb   gr/ye		PE
6 braun / brown		6
7 blau / blue		7
8 schwarz / black	violett / violet	8
9 grau / grey	orange	9
10 weiß / white		Da -
11 rot / red		Da +

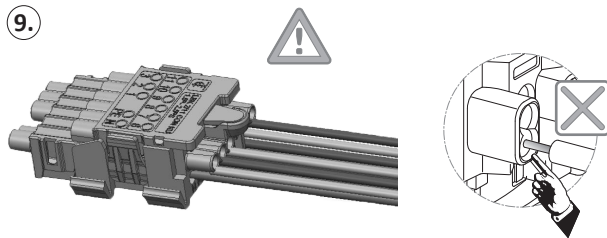
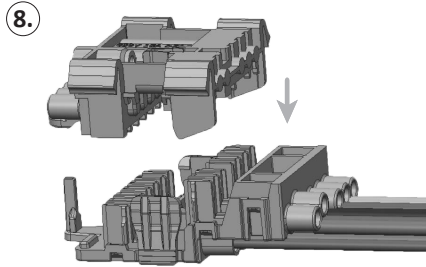
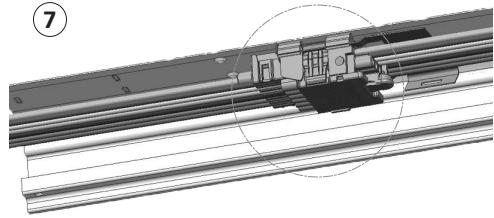
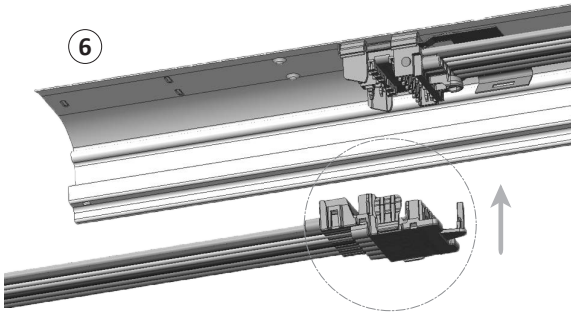

3. DE Leuchtmodul  
 EN Illuminated modul  
 FR Module lumineux  
 ES Módulo de iluminación  
 IT Modulo illuminante

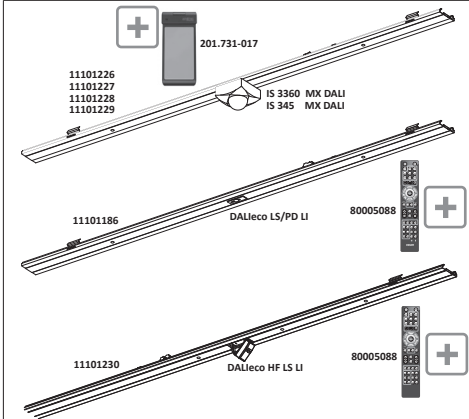
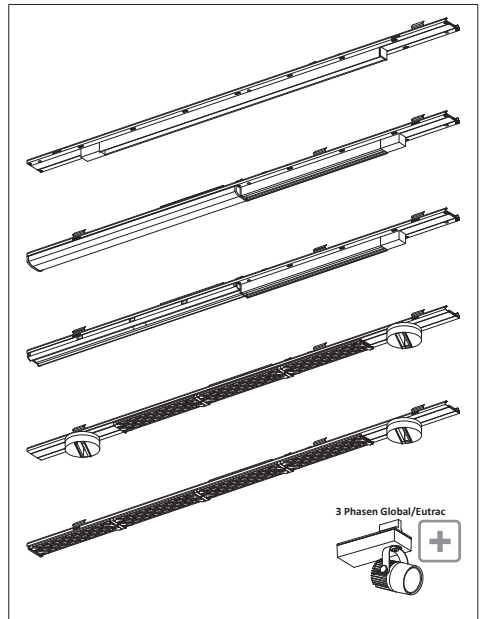
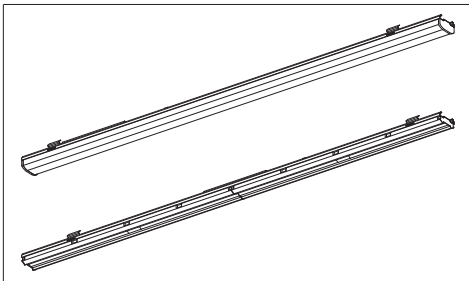
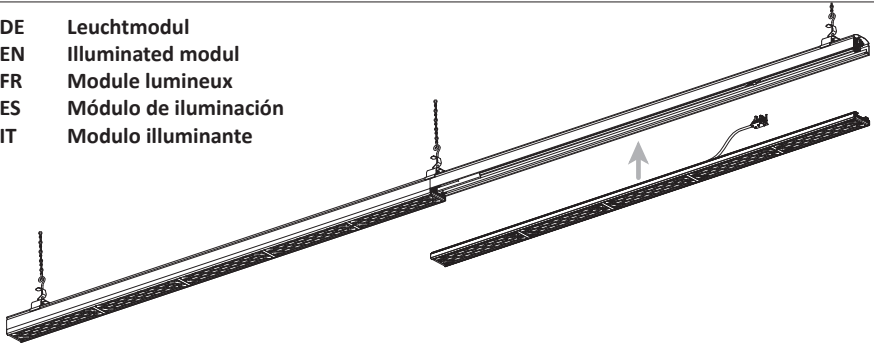

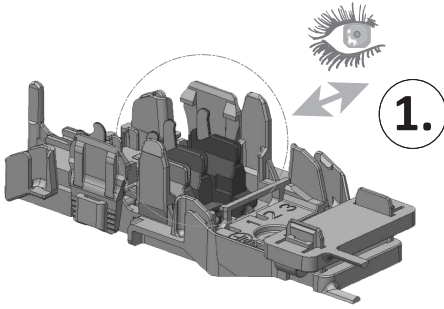

Variante mit variablem Abgriff

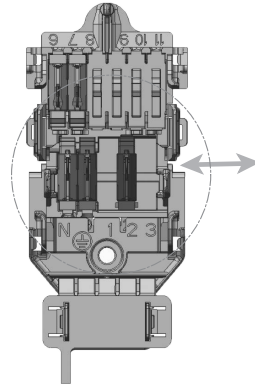

2.

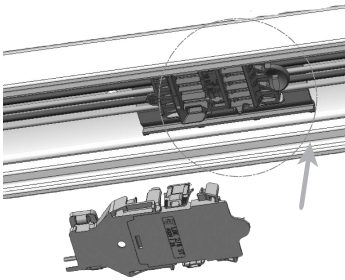

3.

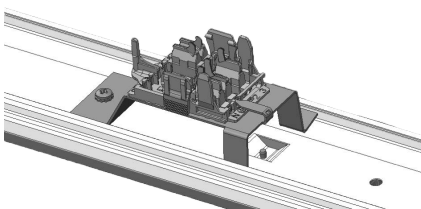

Variante mit festem Abgriff

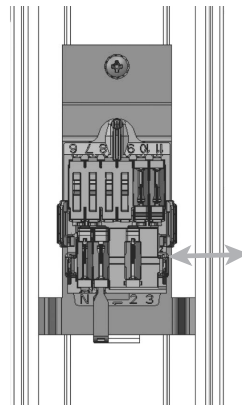

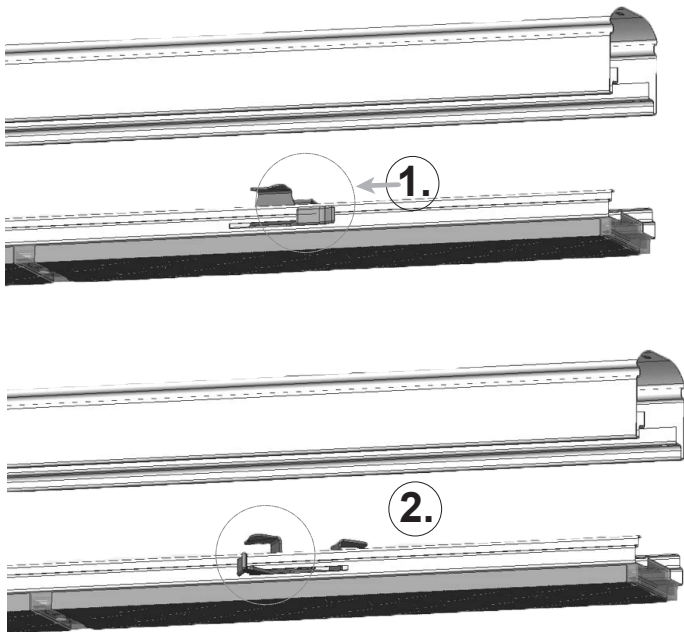

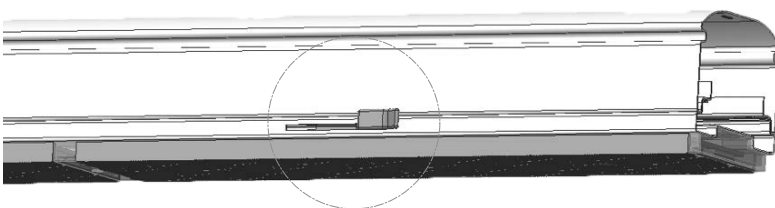
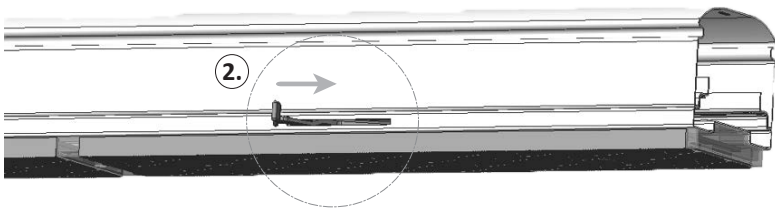
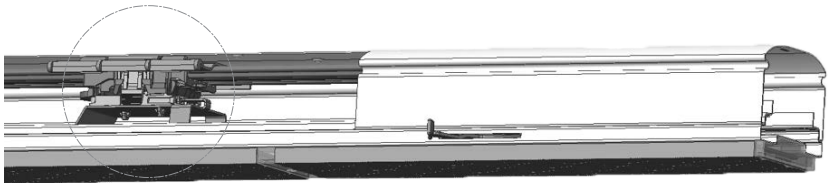
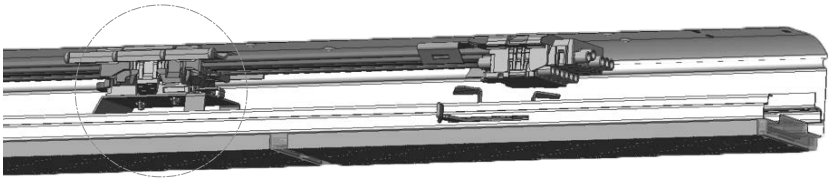
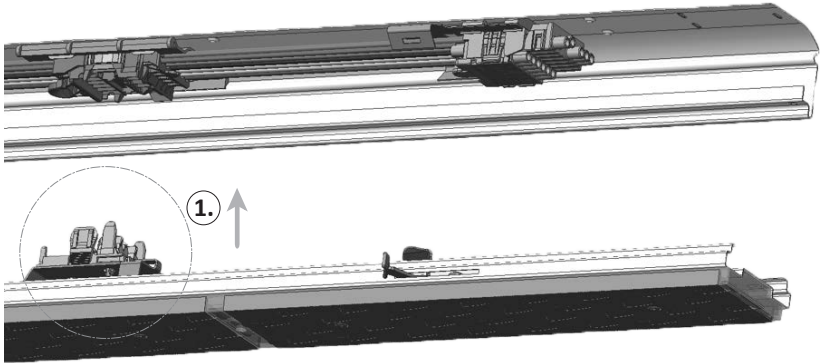

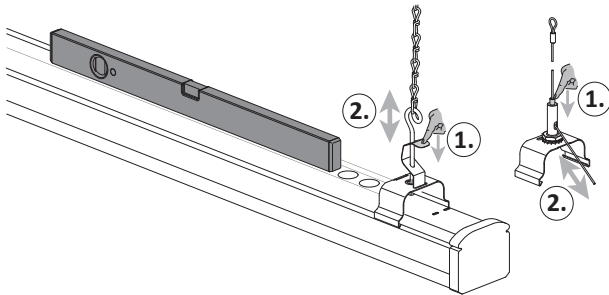
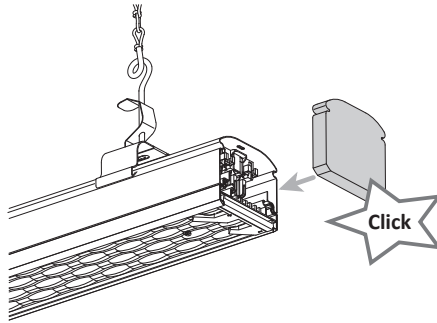
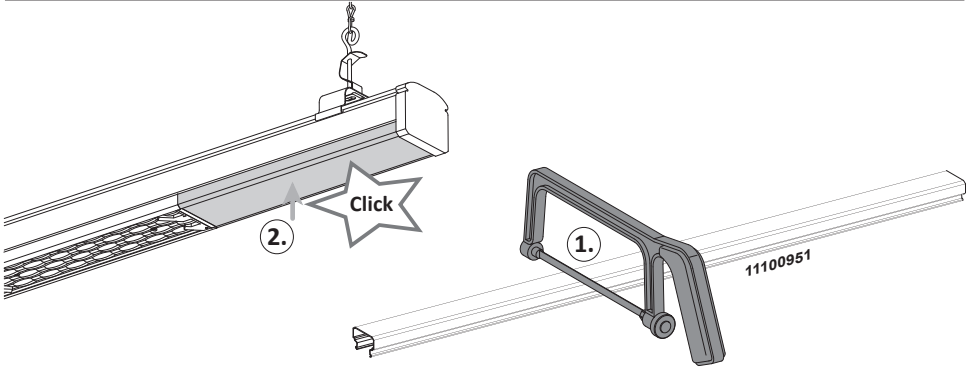

## Demontage

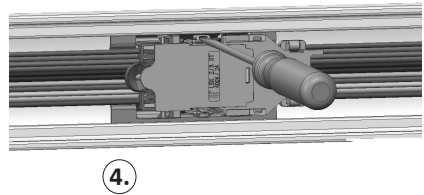
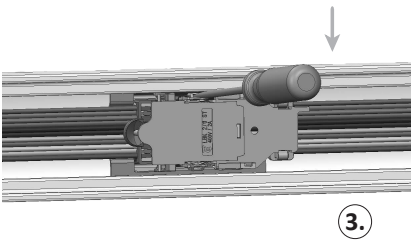
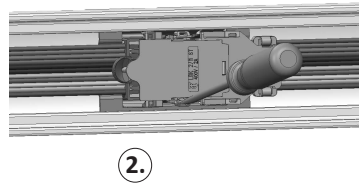
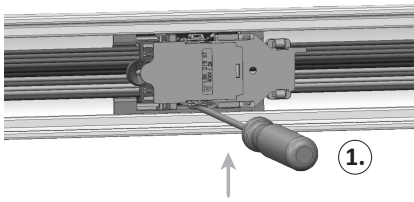
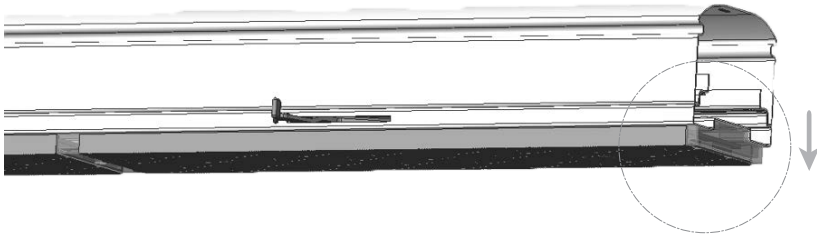
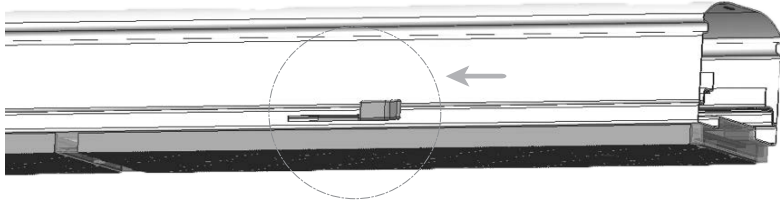

## Technische Daten

### Anzahl Lichteinsätze an Sicherungsautomaten

	OT Fit			OTi DALI			
	35 W	75 W	150 W	35 W	60 W	90 W	150 W
B10	19	16	18	18	15	15	20
B16	30	26	31	30	24	24	31
B25	-	-	-	-	37	29	-